



Ease of Use

The CX25840/1/2/3 can automatically detect, via the use of an on-chip microprocessor, all the worldwide broadcast video and audio standards. This automatic detection is particularly important in geographic regions where different audio standards may be received on a channel-by-channel basis. The devices are preconfigured in default mode for development, verification, and fast prototyping and thus require minimal programming for startup.

Flexible Architecture

The CX25840/1/2/3 video inputs can be programmed for up to eight signal inputs - a maximum of eight Composite Video Baseband Signal (CVBS) input channels. Each of these inputs can be used to support CVBS, S-Video, component video, or broadcast audio inputs. The total number and configuration of video and audio inputs is user defined.

With eight programmable input ports and configurable output ports for 4:2:2 digital video and linear PCM audio, the CX25840/1/2/3 can be used to capture video and audio from TV tuners, DVD players, video cameras, VCRs, game consoles, or any other source of composite Y/C or component (480i) video.

Baseband Audio Support

Output flexibility is not limited to video. The CX25840/1/2/3 offers complete support for baseband audio. The audio output can be programmed to support interfaces of I2S, VIP, or audio over ancillary in the 656 video modes. Additionally, the I2S CLK can act as a master or slave.

The serial audio interface supports programmable master/slave modes and 16- to 24-bit sample widths. The serial audio input port can supply audio samples from an external, baseband audio codec at 32 kHz, 44.1 kHz, 48 kHz, and 96 kHz.

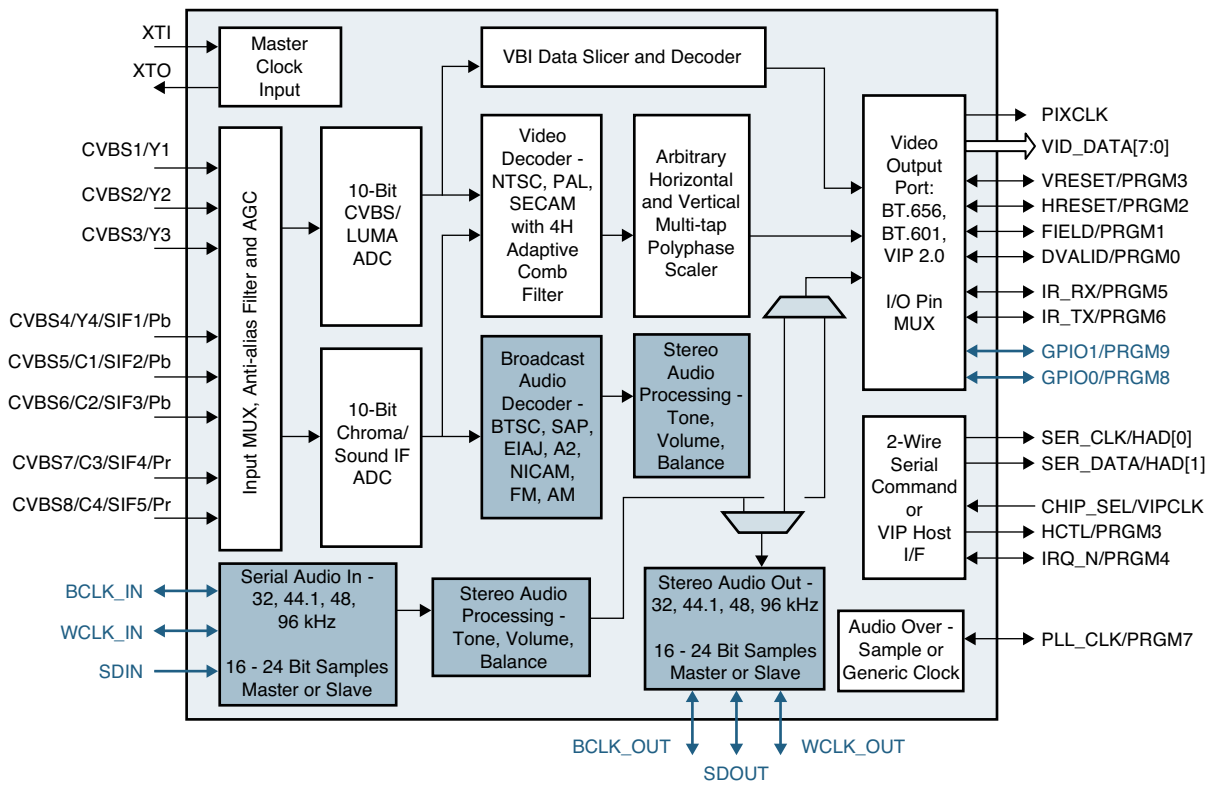

CX25840/1/2/3 System Block Diagram

Part Ordering Numbers

Part Number	Worldwide Audio Decoding	A2, NICAM, FM, AM, Audio Decoding	BTSC (with DBX), EIA-J Audio Decoding	BTSC (without DBX), EIA-J Audio Decoding	Component Video Input	VIP Host Port
CX25840				X	X	X
CX25841			X		X	X
CX25842		X			X	X
CX25843	X				X	X

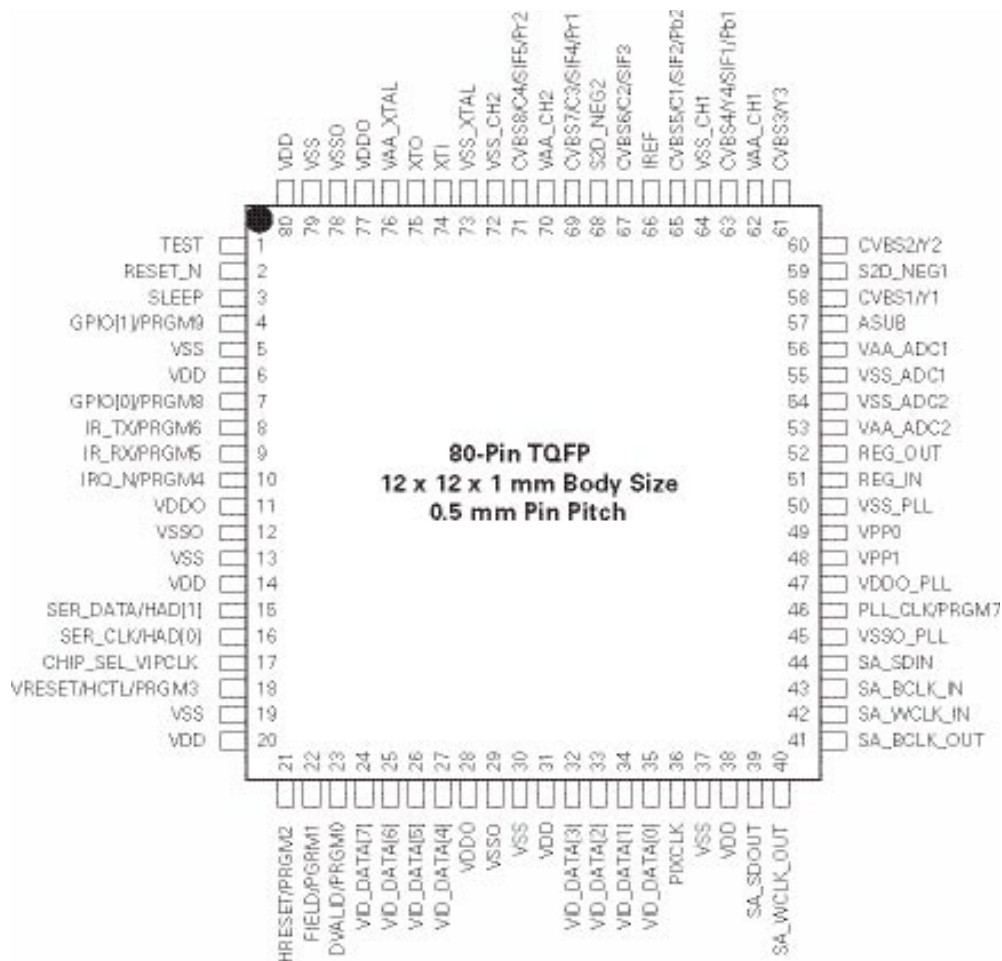

CX25843, CX25842, CX25841, and CX25840 Pinout

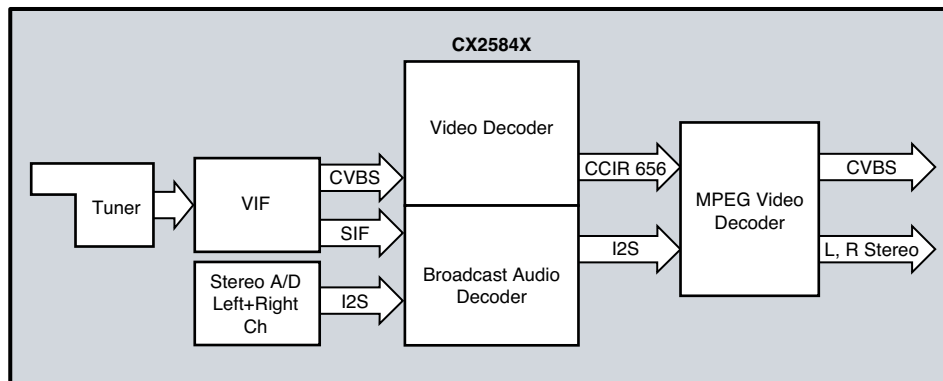

CX25840/1/2/3 Diagram

CX25840/1/2/3 Features

- Auto detection and configuration of worldwide broadcast A/V standards
- Worldwide video standards – NTSC (M, J, 4.43), PAL (B, D, G, H, I, M, N, Nc), SECAM (K, L)
- Worldwide audio standards – BTSC, EIA-J, A2, NICAM, FM/AM
- Full 2 10-Bit ADCs and data path
- Flexible video input mux with integrated anti-alias filtering
- Four line adaptive comb filter for NTSC and PAL
- Flexible video output port - 27 MHz ITU-R BT.656, VIP 2, or ITU-R BT.601 video with separate syncs
- Macrovision detection
- Programmable VBI data slicer for data services such as closed caption, Teletext, and program guides
- Power-up configurable two wire serial command interface or two wire VIP 1.1/2 host port interface
- Multiple audio outputs – serial audio interface I2S or AC97 or embedded as ancillary data in the video stream
- Flexible sample rate conversion on all audio inputs and outputs
- Hardware interrupt to eliminate polling
- Fast locking mode for security camera applications
- Auxiliary clock output – For providing an over sample audio clock locked to the video or for use as a general purpose PLL output
- Infrared transmit and receive logic
- Internal voltage regulation for single supply operation
- Low power
- 80-pin TQFP

Typical Applications

- Flat panel displays
- HDTV
- TV tuners
- DVD players
- Video cameras
- Set-top boxes
- VCRs and PVRs
- Game consoles

© 2003, Conexant Systems, Inc. All Rights Reserved. Conexant and the Conexant logo are registered trademarks of Conexant Systems, Inc. All other trademarks are owned by their respective owners. Although Conexant strives for accuracy in all its publications, this material may contain errors or omissions and is subject to change without notice. **THIS MATERIAL IS PROVIDED AS IS AND WITHOUT ANY EXPRESS OR IMPLIED WARRANTIES, INCLUDING MERCHANTABILITY, FITNESS FOR A PARTICULAR PURPOSE AND NON-INFRINGEMENT.** Conexant shall not be liable for any special, indirect, incidental or consequential damages as a result of its use.

www.conexant.com
General Information:
 U.S. and Canada: (888) 855-4562
 International: (732) 345-7500
 Headquarters
 4000 MacArthur Blvd.
 Newport Beach, CA 92660
 Order# 102205A

